



# **CT Problems & Testing Techniques**

**Peter Fong**  
**OMICRON electronics Corp. USA**

# Content

1. Differences Between Protection and Metering CT's
2. What to Test?
3. What to Watch Out For?
4. New Methods Available

# Protection CT

- Need to operate at high fault current with acceptable accuracy
- Must have high excitation voltage to avoid saturation
- Multiple ratios
- Transient characteristic is important
- Testing mainly concerned with saturation level
- Burden is important

# Metering CT

- Must be accurate over a range of current
- Must be accurate over a range of burden
- Operate in range of load current
- Desirable to saturate early to protect the meter
- Testing mainly concerned with accuracy
- Burden is important

# Protection CT Classes

## C x00

C Rating: Less than 10% Relay Current Error at 20x Rated Current ( $5 \times 20\text{A} = 100\text{A}$ ) into 1, 2, 4, or 8 $\Omega$  Burden

x00: The terminal voltage which the CT must maintain within the C Rating (C100, C200, C400, C800)

# Determining C-Rating

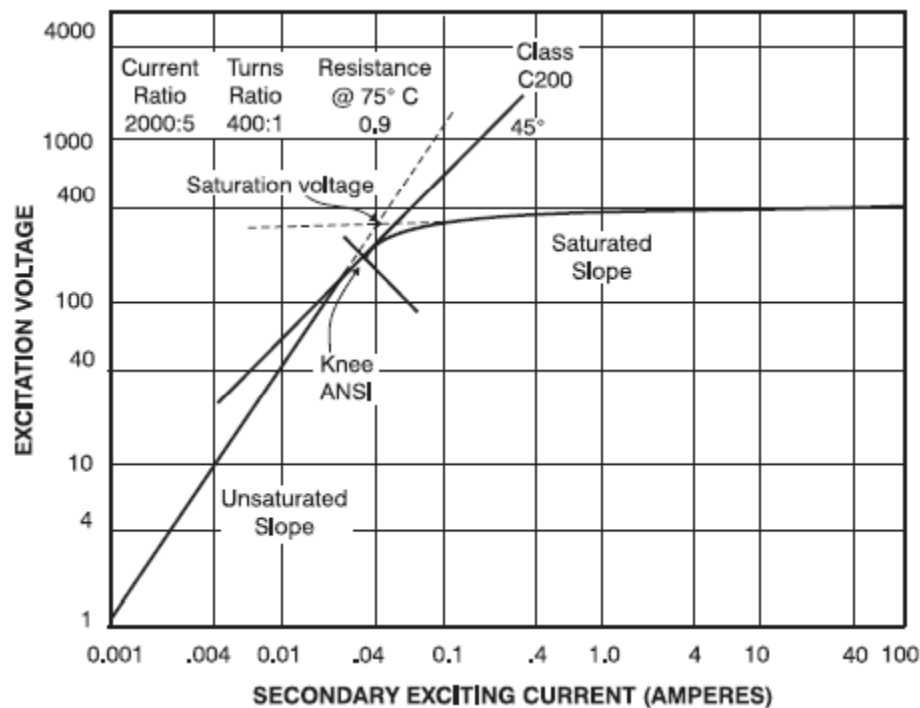

1. Find  $V_{exc}$  where  $I_{exc} = 10A$
2. Calculate  $V_{term} = V_{exc} - 100A \cdot R_{ct}$
3. Round  $V_{term}$  down to nearest 100, 200, 400, 800V corresponding to C100, C200, C400, C800

E.g. For  $R_{ct} = 0.9\Omega$ :

$V_{exc} = 400V$  at  $I_{exc} = 10A$

$V_{term} = 400V - 100V (0.9) = 310V$

→ C200 Rating

# Will the CT Saturate?

Apply Anticipated Fault Current and determine if the voltage impressed on the CT will be greater than the CT rating:

$$V_{CT, Rated} \geq K \cdot I_{sec, rms} \cdot Z_{sec} \quad \text{Eq. 1}$$

where

$V_{CT, Rated}$  = Knee Point, Saturation Voltage, or C Rating, depending on the user's decision

$K$  = User's Safety Margin Factor

E.g. For maximum Fault current of 24,000A into a 1200/5 C200 CT with 1Ω secondary burden and safety margin of 2:

$$I_{sec} = (24,000 \cdot 5) / 1200 = 100A$$

$$310V > 2 \times 100A \cdot 1 = 200V$$

CT is o.k. ✓

# What could go wrong?

With the same C200 CT, we use the 600/5A tap instead:

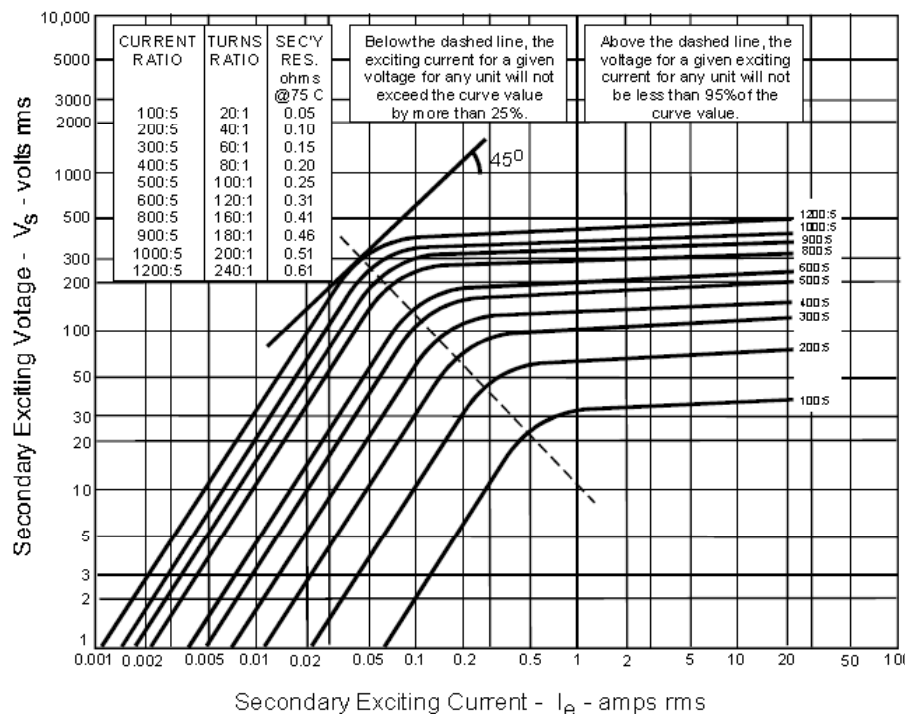

$$V_{term} = 200V - 100V (0.9) = 110V$$

$$I_{sec} = (24,000 * 5) / 600 = 200A$$

$$110V > 2 * 200A * 1 = 400V$$

->> CT not o.k. **X**

\* Be careful about using a lower tap. The combination of a lower kneepoint and higher secondary current could significantly bring down the saturation level of the CT for the same application.

# What else could go wrong?

- Impedance is too high due to long lead lengths
- Poor quality (i.e. low burden rating) CTs are used due to cost or space constraints
- Small loads are put on powerful buses, and CT ratios are selected based on load current rather than fault duty
- Low ratio zero sequence CTs are placed on systems having high ground fault duty
- Unusual burdens (e.g. stabilizing resistors) are placed in the CT circuit

# Metering CT Classes

0.3 B 0.1

Metering Class CT

Accuracy in % (e.g. 0.3%)  
when 100% primary  
current is applied.  
Doubles when 10%  
primary current is applied  
(e.g. 0.6%)

Maximum Burden (e.g. 0.1Ω )

# Rating Factor (RF)

Multiples of Rated Current which the CT can maintain accuracy

Typical RF: 1, 1.5, 2, 3, 4

E.g. 200/5A CT with RF 2 means the CT will maintain its accuracy certification up to 400A

# Secondary Burden

- CT accuracy is rated up to it's maximum burden rating
- Over-burdening will tend to produce error in favor of the customer
- Burden build-up due to aging
  - loose connections
  - corrosion
  - broken stranded wires
- Need to have excess burden capacity during installation

## TABLE. CT System Failure Modes

|   | Failure Mode                             | Test Technique for Failure Mode | Possible Cause of Failure Mode    |
|---|--|---------------------------------|-----------------------------------|
| <b>Wiring Problems</b>                          |  |                                 |                                   |
| 1   | Cross Phasing of a CT                    | Wire Verification               | Installation Error                |
| 2   | Cross Phasing of a CT/PT                 | Wire Verification               | Installation Error                |
| 3   | X1X2/H1H2 Reversal of a CT               | Wire Verification               | Installation Error                |
| 4   | X1X2/H1H2 Reversal of a PT               | Wire Verification               | Installation Error                |
| 5   | Meter Socket Wire Error                  | Wire Verification               | Installation Error                |
| 6   | Loose Connections                        | Burden Test                     | Vibration/Wind/Installation Error |
| 7   | Corroded Connections/Terminals           | Burden Test                     | Moisture                          |
| 8   | Insulation Stripping Error               | Burden Test                     | Installation Error                |
| 9   | Excessive Wire Length/Small Wire         | Burden Test                     | Installation Error                |
| 10  | Broken Wire Strands                      | Burden Test                     | Installation Error                |
| 11  | Meter Overburdened                       | Burden Test                     | Installation Error                |
| <b>Primary/Secondary Current Shunt Problems</b> |  |                                 |                                   |
| 12  | Shorted Turns (Wiring & Leakage Current) | Ratio/Burden Test               | Lightning/Ground Fault            |
| 13  | Shorted Turns (Turn to Turn)             | Ratio/Burden Test               | Lightning/Ground Fault            |
| 14  | Shorted Turns (Turn to Ground)           | Ratio/Burden Test               | Lightning/Ground Fault            |
| 15  | Theft (Secondary Shunt)                  | Ratio/Burden Test               | Tampering                         |
| 16  | Theft (Primary Shunt)                    | Ratio/Burden Test               | Tampering                         |
| 17  | Theft (CT Wrap)                          | Ratio/Burden Test               | Tampering                         |
| 18  | Theft (Primary Tap)                      | Ratio/Burden Test               | Tampering                         |
| 19  | Theft (Secondary Tap)                    | Ratio/Burden Test               | Tampering                         |
| <b>Current Transformer Problems</b>             |  |                                 |                                   |
| 20  | Open Secondary                           | Ratio Test                      | Installation Error/Tampering      |
| 21  | Shorted Secondary                        | Ratio Test                      | Installation Error/Tampering      |
| 22  | Magnetized CT                            | Ratio/Burden Test               | Lightning/Ground Fault            |
| 23  | Dual Ratio Error                         | Ratio Test                      | Installation Error                |
| 24  | Inaccurate Ratio on CT                   | Ratio Test                      | Manufacturer Defect               |
| 25  | Wire Wrap Error on CT                    | Ratio Test                      | Manufacturer Defect               |
| 26  | Inaccurate Rated Burden on CT            | Burden Test                     | Manufacturer Defect               |
| 27  | CT Burden Manufacturer Error             | Burden Test                     | Manufacturer Defect               |
| 28  | CT Mounted Backwards                     | Wire Verification               | Installation Error                |
| 29  | Polarity Dot on Wrong Side of CT         | Wire Verification               | Manufacturer Defect               |
| 30  | Overburdened CT                          | Ratio/Burden Test               | Secondary Burden                  |
| 31  | Overdriven CT                            | Ratio/Burden Test               | Excessive Current                 |
| 32  | CT Phase Shift                           | Wire Verification               | Harmonic Loading                  |

# What To Test?

# Tests for Protection CT

- Commissioning:
  - Ratio, Polarity, Rct, Saturation
  - Secondary Burden
  - If possible for transient studies and network modeling:  
Remenance Flux Factor, Secondary Time Constant
- Maintenance / Fault Investigation:
  - Saturation, Rct
  - Secondary Burden

# Tests for Metering CT

- Commissioning:
  - Ratio and Phase at 0%, 25%, 50%, 100% of Rated Burden
  - Ratio and Phase at 10%, 50%, 100%, ... (up to RF)
  - Calculation of RCF (Ratio Correction Factor)
  - Secondary Burden
- Routine:
  - Same if possible
  - Not convenient - need to send CT back to test lab
  - Can use portable tester for quick verification and send CT back to test lab if in result is suspect

# What to Watch Out For?

# Ratio Test (Bushing CT)

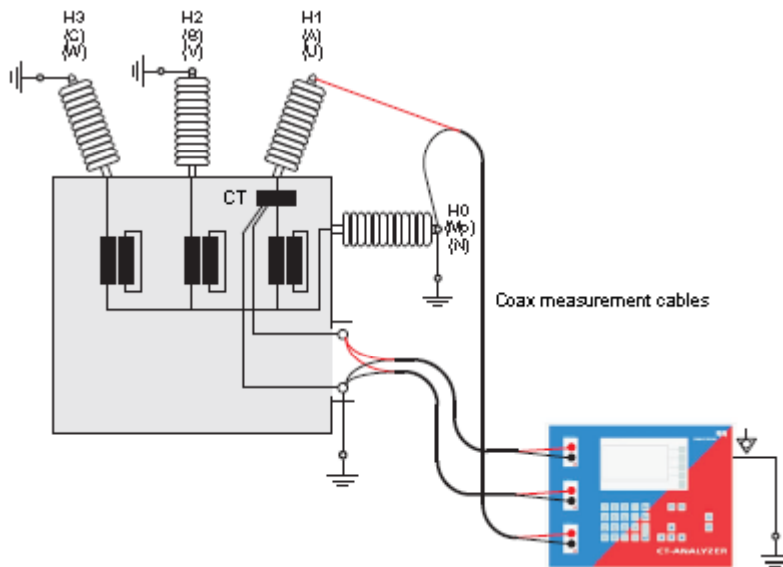

- Short the bushings and windings you are not testing
- Demagnetize the CT before test
- Test Voltage should be below the saturation kneepoint
- Beware of EM interference (use coaxial cable or test at off-frequency)

# Saturation Test

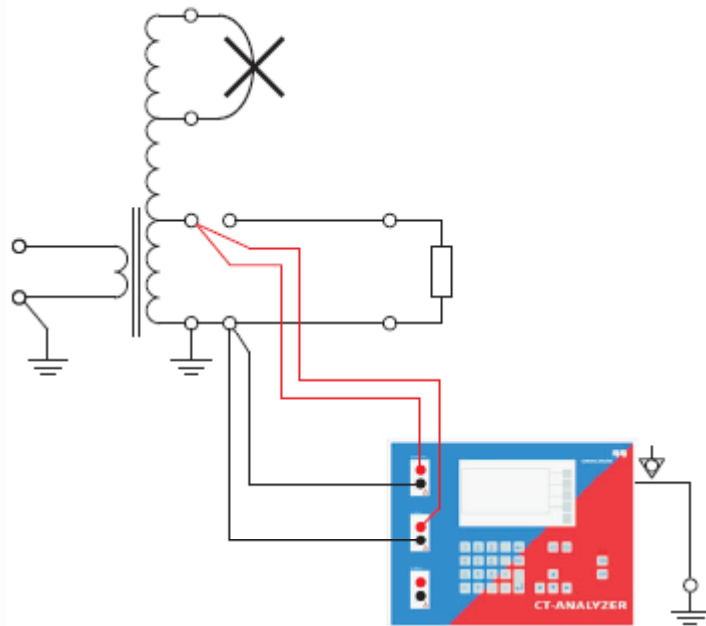

- Test on full winding
- If testing on tapped winding, be careful of auto-transformer effect
- Do not short any taps
- Raise the test voltage slowly
- Lower the test voltage to demagnetize CT
- Beware of insulation level of all parts of CT circuit and use safe test voltage levels

# New Methods (Saturation Test)

- Low voltage, variable frequency saturation test
- Above 120Vac, frequency is reduced to produce higher flux in CT to saturation level
- Result is transformed back to 60Hz
- Can test effective saturation voltage of up to 30kV with test voltage of only 120Vac
- Safe for the CT, Safe for the operator

# New Methods (Ratio Test)

- Magnetizing branch of the CT is measured accurately for losses
- Use measured data for ratio, saturation,  $R_{ct}$  to determine ratio and phase accuracy at different levels of burden and primary current
- No need for external Burden
- On-site verification of metering class CT possible (to 0.1 class)

# Summary

- CT is not so straight-forward
- Protection and Metering CTs have different considerations
- Choose the tests that are appropriate to the type of CT
- Take care of on-site conditions when testing CT
- New methods are available to make CT testing safer and easier

# Thank you for your attention!

